

1999 JEEP®





1941

Production begins on a small, 4WD military vehicle. Over 700,000 are produced during World War II.



1962

The 1963 Wagoneer is launched — the first “from the ground up” luxury civilian sport-utility vehicle.



1973

The 1974 Cherokee debuts and includes Quadra-Trac®, the first fully automatic full-time 4WD system.



1983

The first in its class with a choice of two or four doors and two available 4WD systems, the 1984 Cherokee arrives.



1986

The new 1987 Wrangler debuts, replacing the CJ-7.



1992

The 1993 Grand Cherokee, with three available 4WD systems, sweeps the most prestigious awards in its class upon introduction.

A HERITAGE OF FOUR-WHEEL-DRIVE EXCELLENCE

These are the milestones of a legend — as untamed and rugged as the American spirit itself. For nearly 60 years, their four-wheel-drive (4WD) capability has transformed nervousness and trepidation into ringing choruses of “I knew I could, I knew I could, I knew I could.” They have made vistas of incredible beauty and peaceful solitude just a journey away. And as easily as they discover the hiding spots of the world, they instill utmost confidence in the daily commute. For 1999, *they* are the legendary Jeep. Wrangler, rugged Jeep Cherokee and all-new Jeep Grand Cherokee — the newest Jeep milestone that will lead this heritage of four-wheel-drive excellence into the 21st century. Introducing **the most capable sport utility ever.**



THE ALL-NEW 1999 JEEP GRAND CHEROKEE

Table of Contents

Jeep Grand Cherokee
Pages 4-13

Jeep Cherokee
Pages 14-21

Jeep Wrangler
Pages 22-27

Selected Standard Features
Pages 28-29

Jeep Accessories from Mopar, Jeep Provisions, Customer One Care™, Leasing
Pages 30-31



Clockwise from bottom: Jeep Grand Cherokee Limited in Sienna, Jeep Cherokee Sport in Desert Sand and Jeep Wrangler SE in Flame Red. Alabama Hills, California

“Mechanically speaking, the big news is the 4.7-liter V8 ... designed and developed in concert with the new four-speed 45 RFE transmission. The gearbox actually has five ratios — second gear has two, at 1.5 and 1.67:1, with the transmission choosing the ratio based on speed and throttle position.”

— *AutoWeek*



“The introduction of the Quadra-Drive System on the 1999 Jeep Grand Cherokee changes the rules of four-wheel drive so dramatically, it may never be the same.”

— *Automotive Industries*

THE ALL-NEW JEEP GRAND CHEROKEE
THE MOST CAPABLE SPORT UTILITY EVER*

*Based on AMCI overall on- and off-road performance tests using Grand Cherokee with optional V8, Up Country Suspension Group and Quadra-Drive.™

JEEP® GRAND CHEROKEE

When you take the 4x4 further than anyone else, skeptics abound. So the all-new 1999 Jeep Grand Cherokee was tested against 23 sport-utility vehicles for total vehicle capability. It emerged with a rock-solid claim that speaks to its on- and off-road mastery: **The most capable sport utility ever.** Grand Cherokee does everything you'd expect of a Jeep vehicle — reach the unreachable, scale the unscalable, amaze you along the way — but in some ways you'd never expect. You'll find it where we've always been: where others can't go and don't dare try. And with technological advancements fueling its Jeep passion for adventure, the all-new Grand Cherokee is the fullest realization yet of where we're going.

Jeep Grand Cherokee Limited in Sienna
Near Stowe, Vermont

QUADRA-DRIVE™

The all-new Quadra-Drive System transfers torque rear to front and side to side to maintain traction and control.

In normal driving, it sends engine torque through the new Quadra-Trac II™ (NV247) on-demand transfer case* to the all-new rear Vari-Lok™ progressive axle.† The moment a rear wheel loses grip, however, a gerotor coupling in the rear axle transfers torque to the other rear wheel. If that wheel cannot continue momentum, a gerotor pump in the transfer case sends that torque to the all-new front Vari-Lok progressive axle. There, a gerotor coupling is capable of transferring 100 percent of the developed engine torque to just one wheel. This reaction and torque transfer is continuously monitored and maintained by Quadra-Drive regardless of which wheel experiences loss of traction — and it is done progressively, silently and smoothly.



Jeep Grand Cherokee Laredo in Taupe Frost
Alabama Hills, California

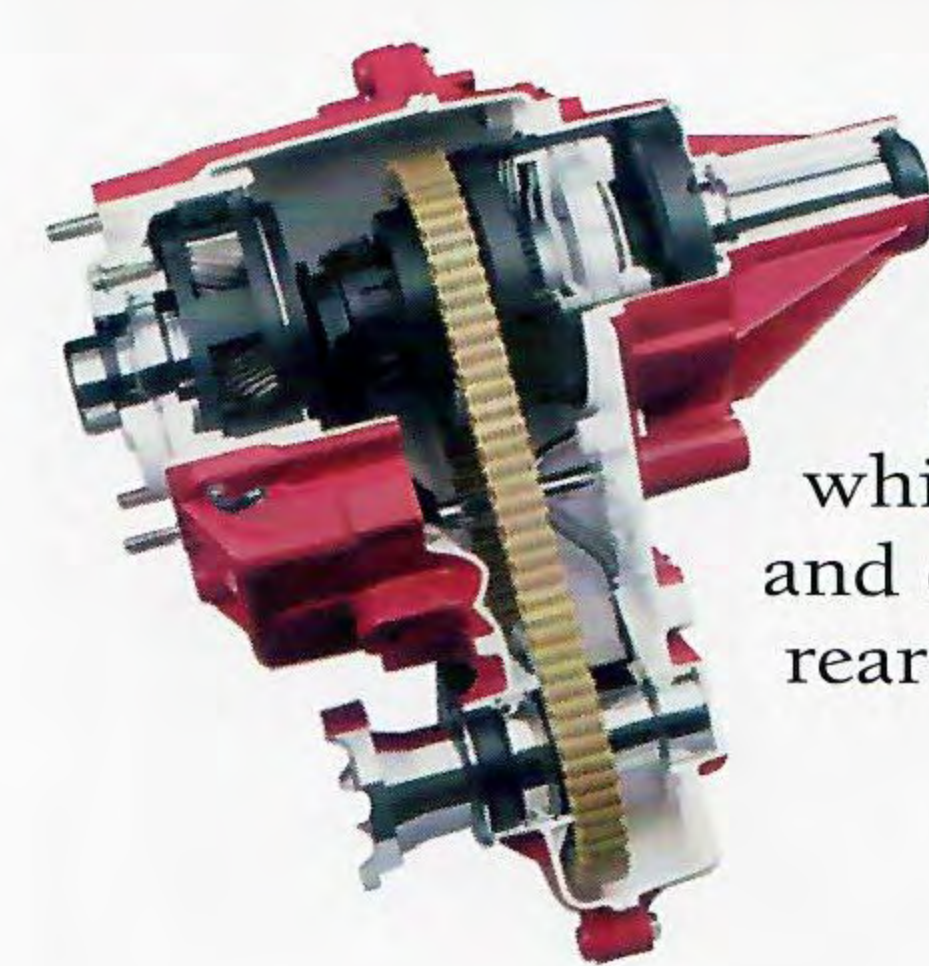

A key element in the Quadra-Drive System is the all-new Quadra-Trac II on-demand transfer case, which transfers torque quickly and quietly between front and rear axles.

Grand Cherokee is the first vehicle ever whose transfer case and available Vari-Lok progressive axles all feature speed-sensing torque-transfer devices. That means torque can be transferred rear to front between axles and side to side on both axles.

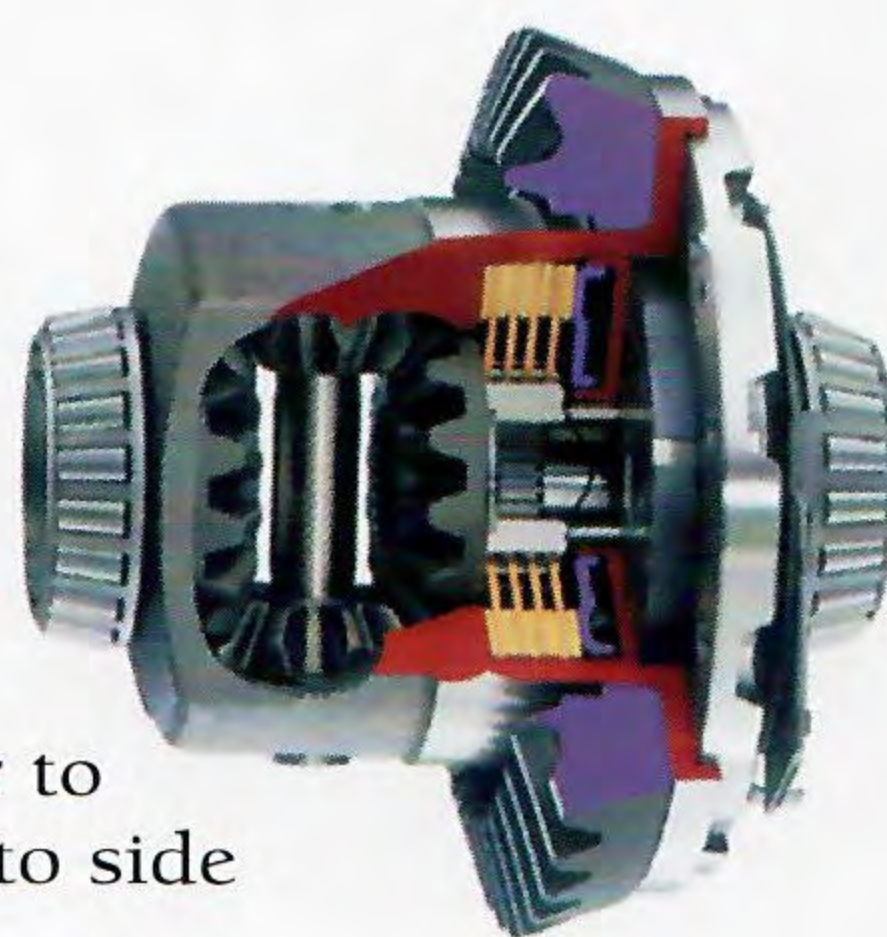

1 Two wheels on ice on the same side of the vehicle would mean a call for help in most 4x4s. In a Grand Cherokee equipped with the available Quadra-Drive System, the front and rear progressive axles transfer torque, if necessary, to the wheels with traction, giving you power to continue your journey.

2 Since Quadra-Drive is capable of transferring 100 percent of the developed engine torque to any one wheel, even three wheels on ice would not stop the all-new Grand Cherokee.

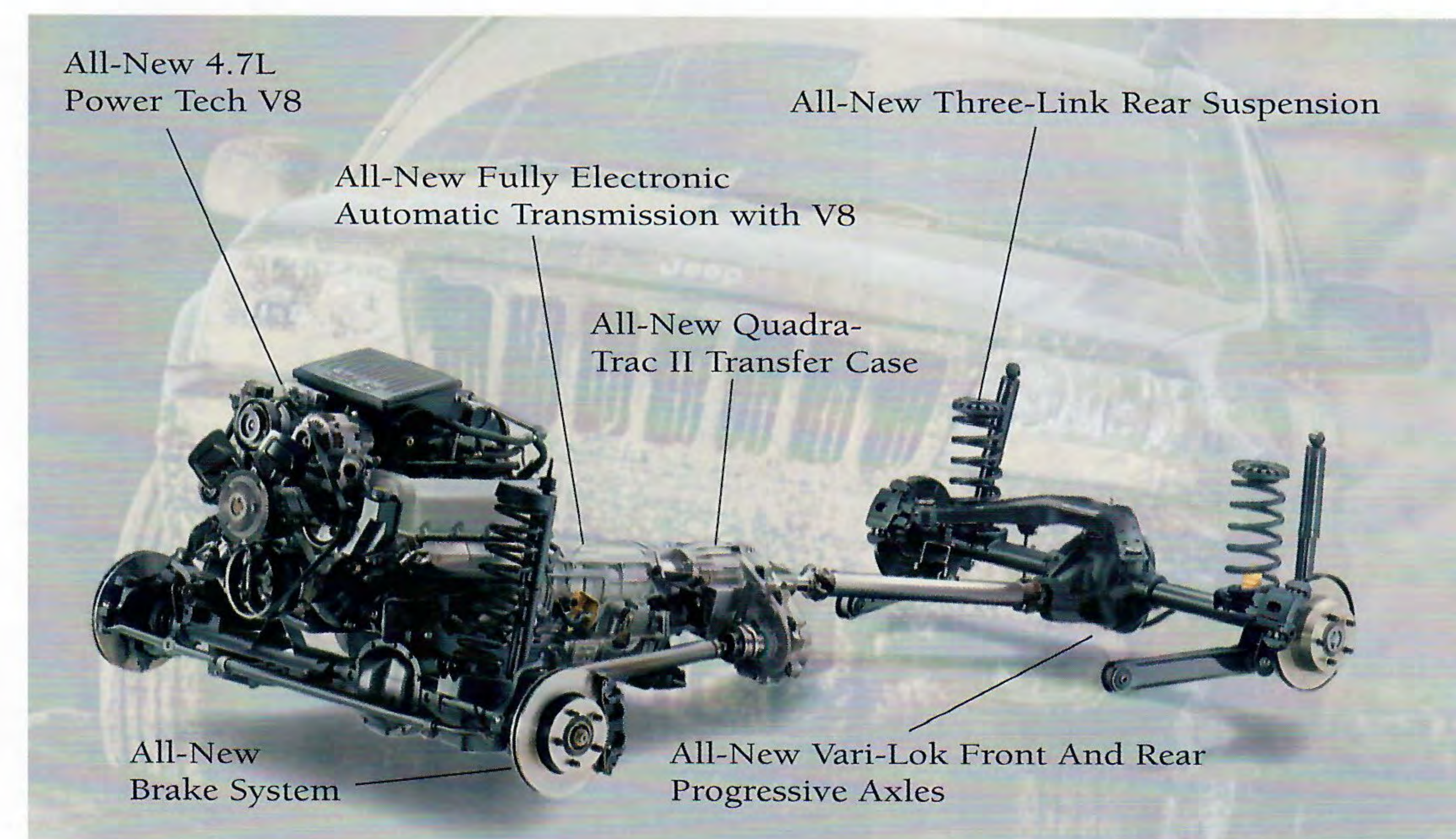

All-New 4.7L Power Tech V8

All-New Three-Link Rear Suspension

All-New Fully Electronic Automatic Transmission with V8

All-New Quadra-Trac II Transfer Case

All-New Brake System

All-New Vari-Lok Front And Rear Progressive Axles

Jeep® engineers carried a “systems” approach to the very heart of the all-new 1999 Grand Cherokee. While each component of the driveline and chassis listed here is indeed unique, they work together as a single, cohesive unit. Their mission: keep Grand Cherokee under driver control and moving forward no matter what obstacles lie in its path.

*The Quadra-Trac II transfer case is standard on four-wheel-drive Limited models and with V8 engine, optional on four-wheel-drive Laredo models.

† Vari-Lok progressive axles are included with optional Quadra-Drive four-wheel-drive system.

POWER AND PERFORMANCE

Grand Cherokee's Quadra-Coil™ suspension and all-new drivetrain* perform powerfully on- and off-road. With a wide range of gear ratios that includes an alternate second gear to help smooth downshifts, the multispeed 45 RFE (rear-wheel-drive fully electronic) automatic transmission precisely applies the 4.7L Power Tech V8's exceptional might — all 235 horsepower of it. A quieter, more luxurious ride results from the new three-link rear suspension, wider spacing of the tie-rod points, modified coil springs at all four corners and standard 16-inch wheels and tires. And with new steering linkage, gear, and optimized steering geometry, these ride and handling improvements reach the driver more accurately through more precise steering response and improved control from behind the wheel.

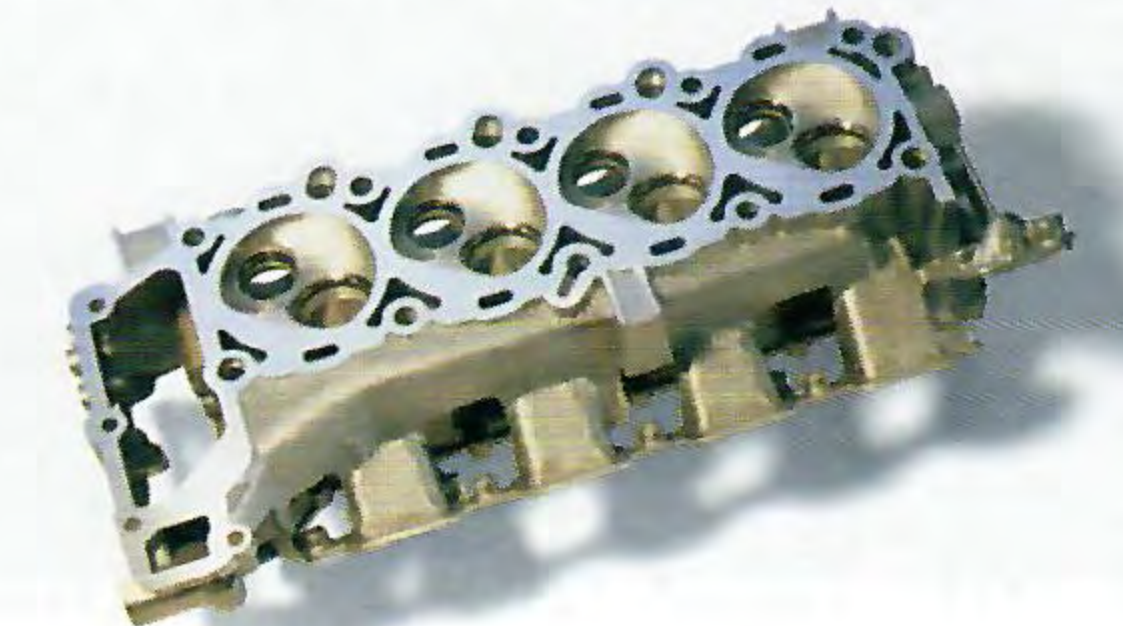

*4.7L Power Tech V8 engine mated to a multispeed electronically controlled 45 RFE automatic transmission. Optional on Laredo and Limited four-wheel-drive models.

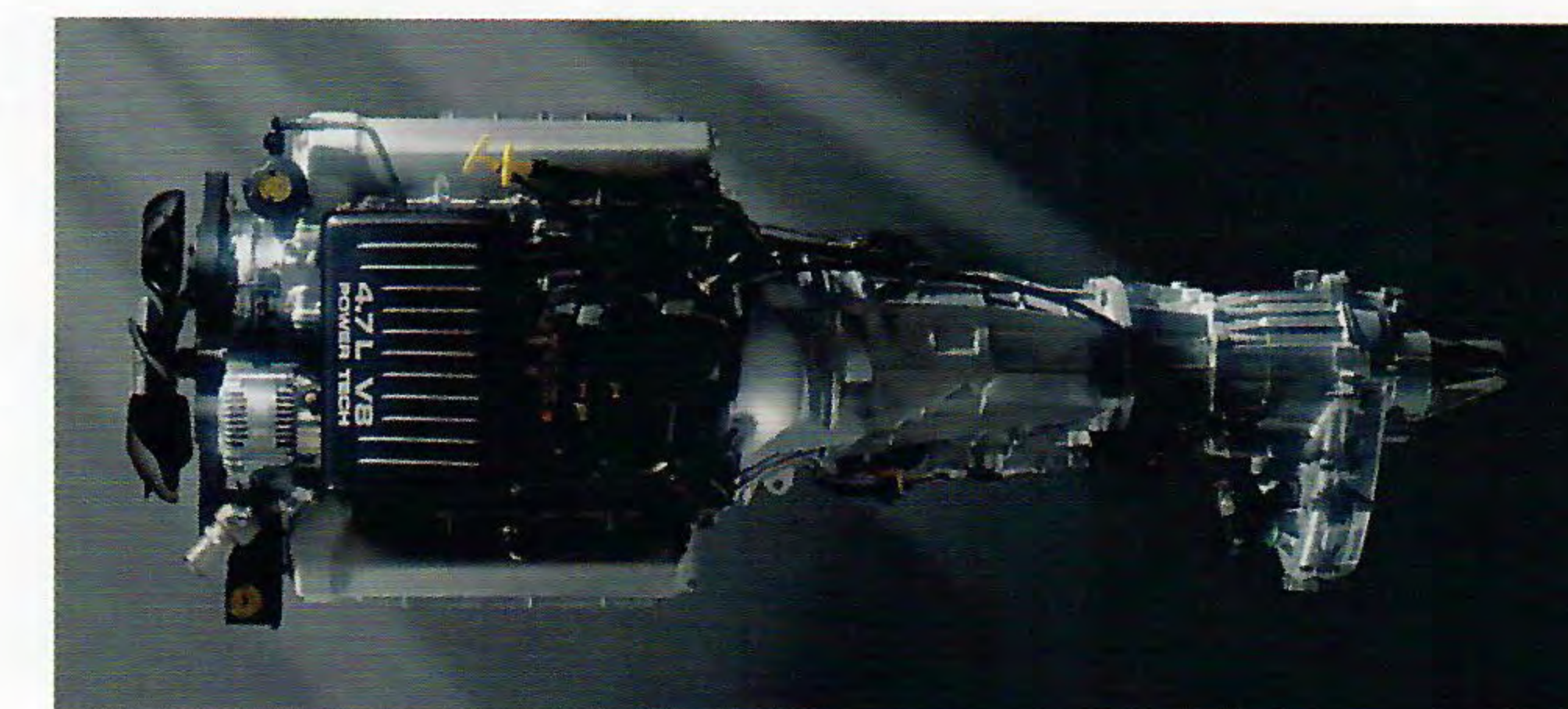

The 4.7L Power Tech V8 engine offers more horsepower, faster acceleration, better fuel economy, reduced emissions and improved durability — yet weighs 54 pounds less than the engine it replaces.



In addition to a running ground clearance of 9.1 inches with the available Up Country Suspension Group, the all-new Grand Cherokee has improved its suspension articulation, allowing for a more comfortable ride both on- and off-road.



The new quad-halogen headlamps on Grand Cherokee provide a wider beam pattern and greater range than the previous system.

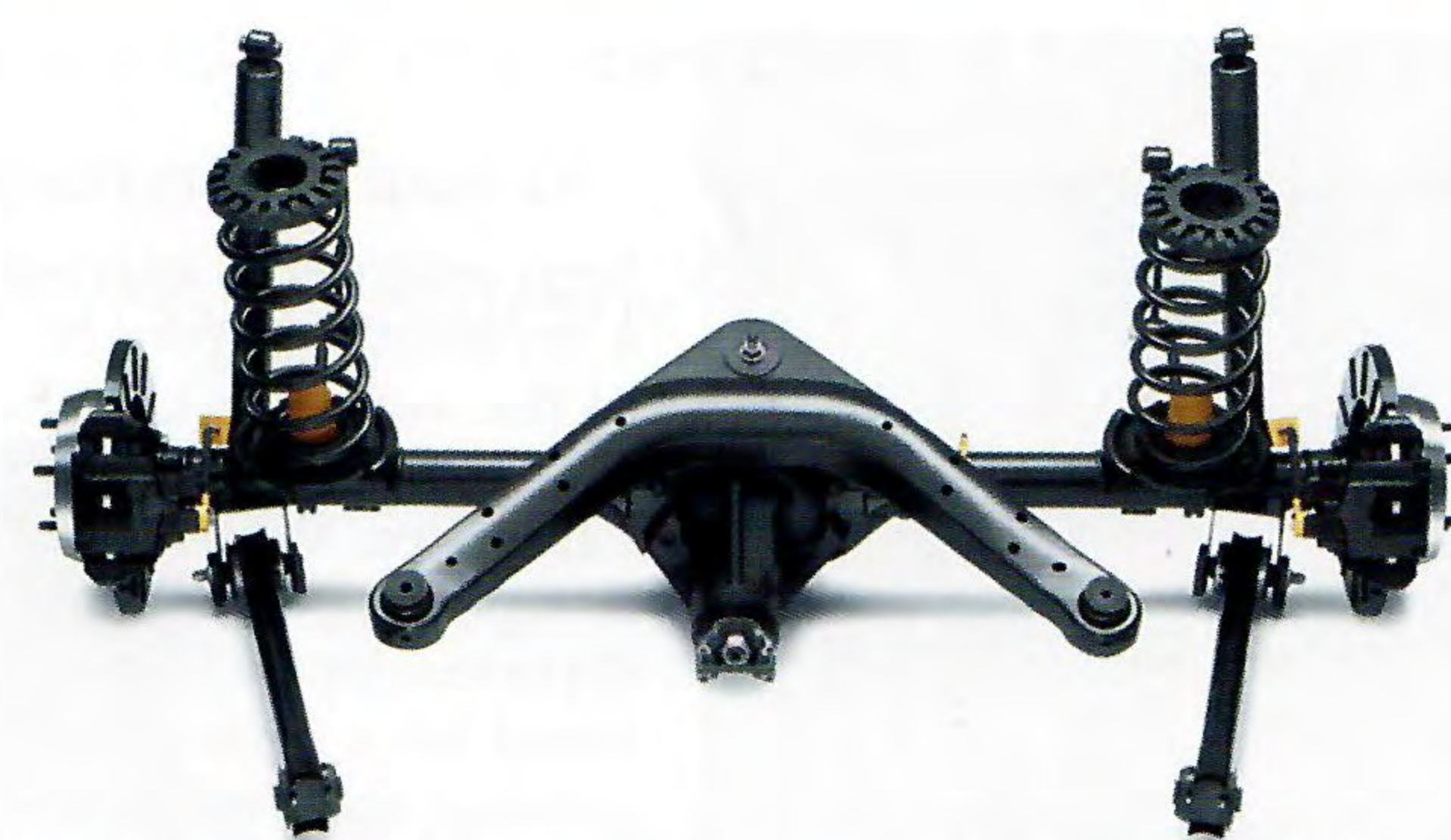

A new three-link rear suspension with single A-shaped upper control arm improves rear axle articulation and lets Grand Cherokee corner flatter in turns.

The 4.0L Power Tech I-6 is standard on Laredo and Limited. Enhancements for 1999 have increased output to 195 horsepower and torque to 230 pound-feet. It is teamed with an electronically controlled four-speed automatic transmission.

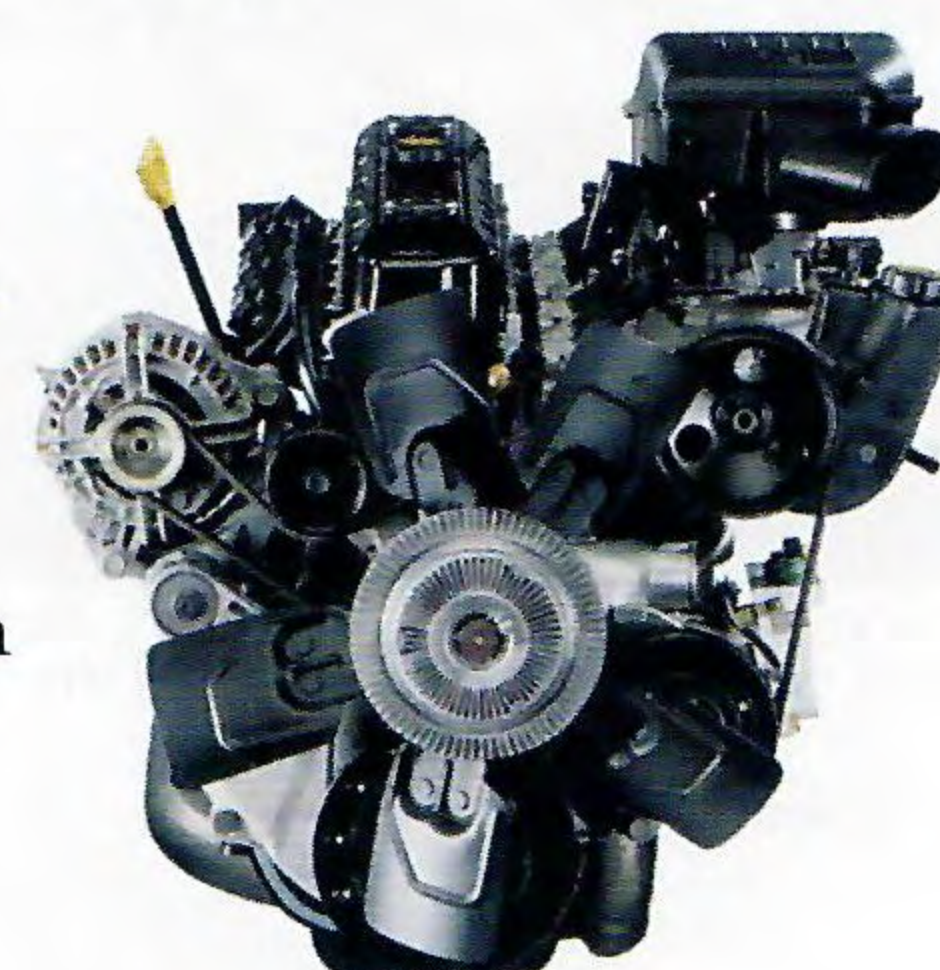

Grand Cherokee's stiffer, stronger, more durable UniFrame means less resonance (vibration) reaches you in the vehicle, providing smoother travel off-road and better ride and handling on it.

PREMIUM ACCOMMODATIONS

Grand Cherokee's all-new interior really comes together at its focal point — the center.

The instrument panel's center pod contains large, rotary controls for the first-ever Infrared Dual Zone Climate Control system (on Limited models), an auxiliary power outlet and centrally located radio knobs with soft-touch buttons. A floor-mounted center console features dual front and rear cup holders and a large covered storage bin with tissue pack and pen holders molded into the lid's underside. Above center, a HomeLink® Universal Transmitter in Grand Cherokee Limited's overhead console allows you to control your garage door, estate gate and home security system from the driver's seat. All this (and more) innovation can be accessed in one place — Grand Cherokee's comforting interior environment. After all, we designed it for the real center of attention. You.



Premium leather-trimmed seat surfaces are standard on Grand Cherokee Limited and available in Camel (shown), Agate or Taupe.



Sensors in Grand Cherokee Limited's Infrared Dual Zone Climate Control system continually measure surface temperatures in the zones indicated for the driver (orange) and front-seat passenger (red) — making adjustments in airflow and temperature when necessary to maintain the selected comfort level.

The all-new instrument panel on Grand Cherokee has a high level of styling and definition. On Limited (shown), a high-gloss woodgrain finish accents the center console and instrument panel moldings.



AUTO DOOR
LOCKS? YES

FLASH LIGHTS
WITH LOCKS?Y

REMOTE LINKED
TO MEMORY? YES

An available all-new overhead console gives you the freedom of programming up to 13 electronic preferences, three of which are shown.



The cloth interior on Grand Cherokee Laredo is available in Taupe (shown), Agate or Camel. A leather-trimmed interior is optional.



With the rear seats up, Grand Cherokee offers 39.0 cubic feet of cargo space. Fold them down and 72.3 cubic feet are available. And with the spare tire now under the rear load floor, that space is more usable than ever for your favorite gear or golf clubs.

Properly secure all cargo before transporting.



A removable lid that rests flush with the surrounding rear load floor covers the spare tire well, while a molded seal at the rear minimizes transfer of road noise into the interior.

VERSATILITY

Take a peek inside the all-new Grand Cherokee and you may ask yourself: where's the spare?

It's there, in a spare tire storage area that's under the rear load floor — a feature you won't find on any other domestic 4x4 in its class. And even if you never need the spare, you'll appreciate the increased load-floor width. To make that space more accessible, new Easy-Fold rear seats include height-adjustable, hinged head restraints that fold forward for ease of use. More prime examples of the lengths Jeep® engineers went to in making Grand Cherokee more versatile than ever.



New for 1999, Grand Cherokee's cargo area provides room for an optional CD changer with 10-disc capacity that's mounted in a covered compartment on the right cargo area trim panel.

Color and Trim



Sienna Pearl Coat



Flame Red



Taupe Frost Metallic



Champagne Pearl Metallic



Everglade Pearl Coat



Bright Platinum Metallic



Deep Slate Pearl Coat



Black



Stone White

Dayton/Regina Cloth. Standard on Laredo. Shown in Taupe, also available in Agate and Camel.

Wanderer II premium leather trim. Optional on Laredo. Shown in Agate, also available in Taupe and Camel.

Wanderer II premium leather trim. Standard on Limited. Shown in Camel, also available in Agate and Taupe.

JEEP® CHEROKEE

Isn't it reassuring to know that Jeep Cherokee, the first four-door 4x4 in its class, continues to place off-road prowess at the top of the priority list. This can't be said of the many manufacturers who have rushed to enter the sport-utility vehicle market and made concessions to off-road capability: no low-range four-wheel drive, little power, minimal ground clearance. The list goes on. And stops cold with the four-wheel-drive Cherokee. Ample ground clearance, generous approach, departure and breakover angles, a Quadra-Link solid-axle, coil-spring front suspension and UniFrame construction are standard. Axle ratios are geared low enough for off-road mastery. Powerful engines feature loads of low-end torque, and both the Command-Trac® and Selec-Trac® four-wheel-drive systems include low range. Honest, genuine 4x4 freedom — for a lot less than you might imagine. That's Jeep Cherokee for 1999.

Jeep Cherokee Sport in Desert Sand
Mogul Peak, California

“... the Jeep Cherokee is a raging bargain, offering driving enjoyment, off-road ability, overall function, and a refreshingly wallet-friendly sticker price.”

— *Motor Trend*

“... sliding behind the wheel of a Cherokee is a bit like slipping into a comfortable pair of Dockers® Khakis and a denim shirt. In a world of designer-label overkill, the Cherokee is refreshingly honest.”

— *Open Road:
The 4WD Adventure Magazine*



OFF-ROAD READINESS

Cherokee's remarkable versatility includes the choice of two proven four-wheel-drive (4WD) systems. Selec-Trac®, standard on 4WD Limited and optional on Classic and Sport (requires 4-speed automatic transmission), is a full-time system with a convenient 4 FULL-TIME mode that can remain engaged over all road surfaces. Command-Trac®, standard on SE, Sport and Classic 4WD models, is a part-time system for use whenever extra traction is required. Up front, Cherokee's Quadra-Link suspension is anchored by a rugged solid axle (beam axle on two-wheel-drive models). Together with coil springs and four locating arms, this setup gives Cherokee precise handling, stability and control on a variety of driving surfaces.



With Selec-Trac (shown) and Command-Trac, you can shift-on-the-fly into high range four-wheel drive at speeds up to 55 mph. For optimum torque and control in severe conditions, both have a four-wheel-drive low range.



With up to 11.7 inches of minimum running ground clearance and 38.4-degree approach, 31.2-degree departure and 24.5-degree breakover angles, Cherokee can tackle the roughest terrain without the undercarriage making contact with the ground.



Jeep® Cherokee Classic in Flame Red
Morrison Jeep Trail, Wyoming

In the Selec-Trac 4 FULL-TIME mode, 48 percent of engine power is sent to the front axle and 52 percent to the rear. Because the driveshafts rotate at different speeds, you have the added convenience of remaining in this mode year-round over any road surface — including dry, paved roads — instead of having to shift back and forth between two- and four-wheel drive as road conditions change.

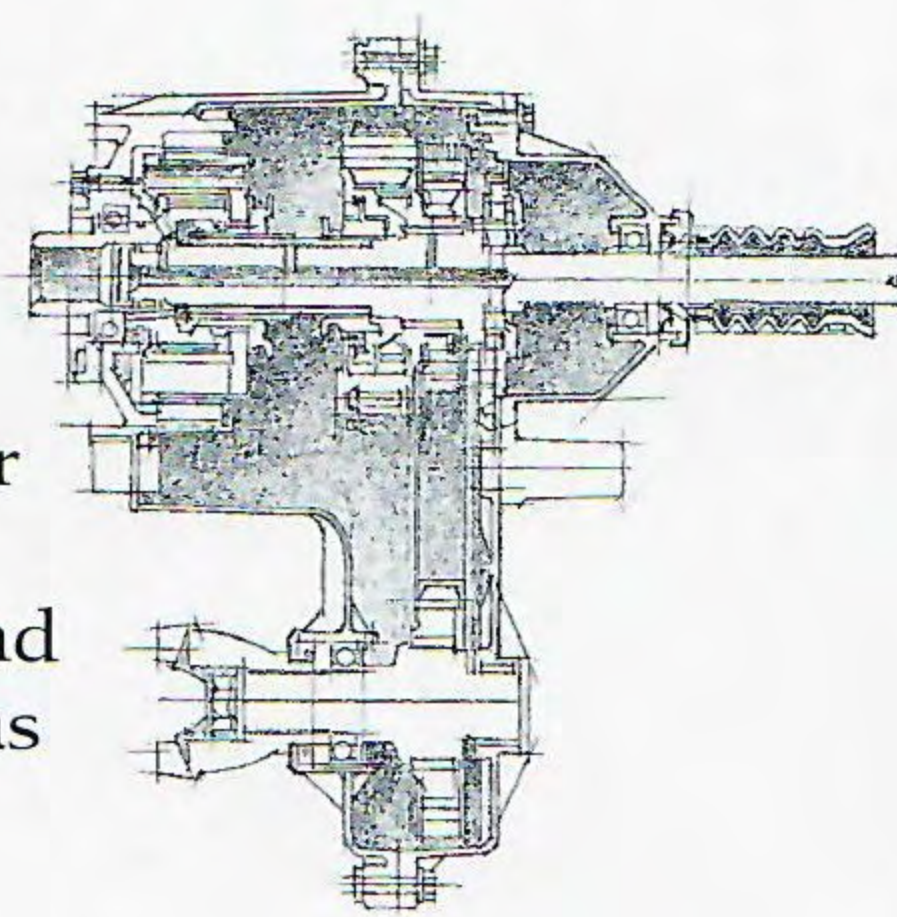

In the Selec-Trac 4 PART-TIME mode, the center differential mechanically locks the front and rear driveshafts together, which then rotate at the same speed for maximum traction. Since this position is designed for temporary use when extra traction is required, shift back into two-wheel drive (2WD) when returning to dry, paved surfaces.

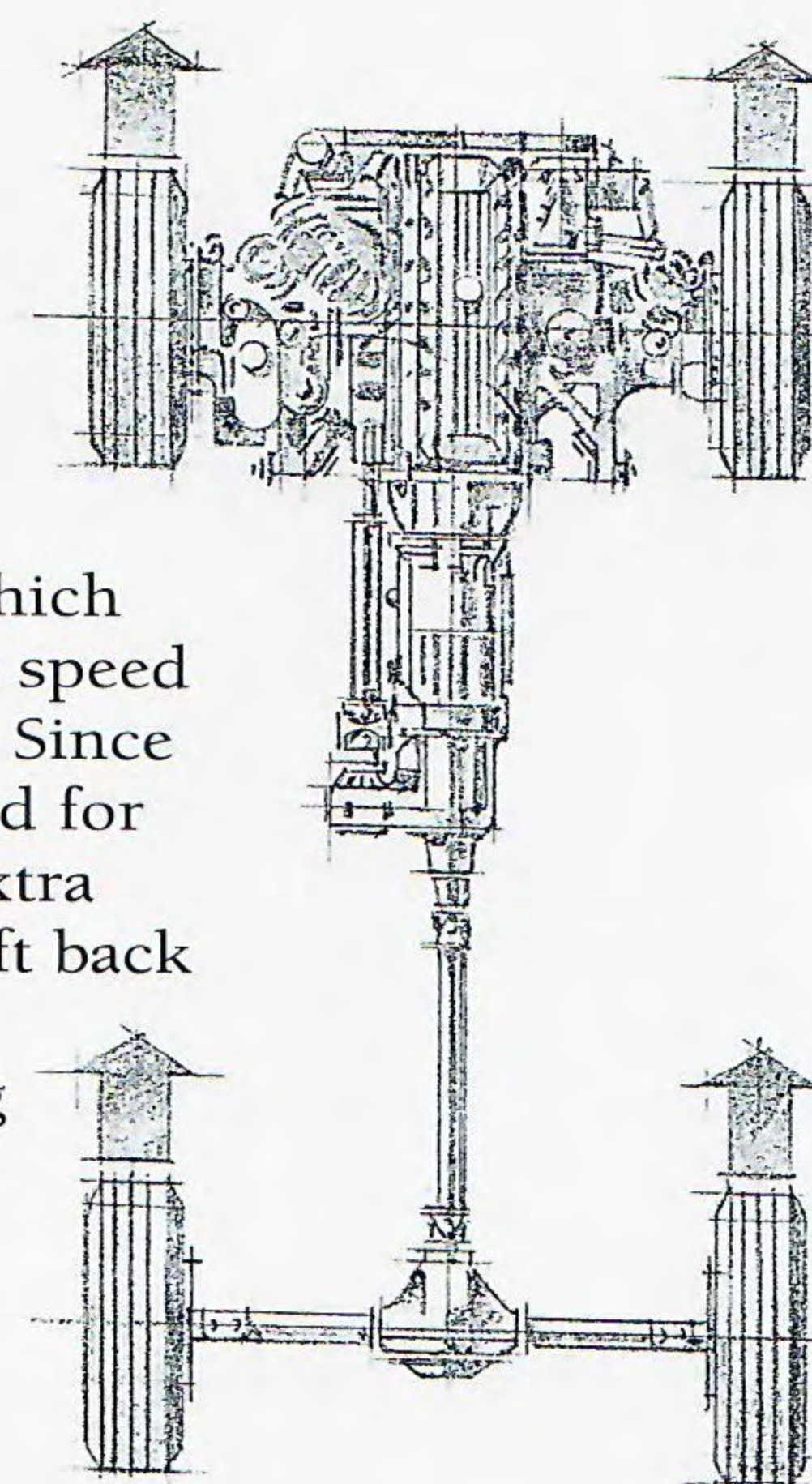

POWER

For a versatile performer like Jeep® Cherokee, power serves many functions. With the mighty 4.0L Power Tech I-6 engine (standard on Sport, Classic and Limited, optional on SE), there's passing power and quick acceleration for the open road, pulling power for a boat or horse trailer, and plenty of low-end grunt for hardy trail work. That's because its in-line design supplies peak torque (pulling power) at a usable, low-speed range. Transmissions include a five-speed manual standard on SE and Sport, optional three-speed automatic (on two-wheel-drive SE models with the 2.5L Power Tech I-4 engine) or standard four-speed automatic featuring electronic controls and a lockup torque converter on Classic



and Limited (optional on SE with the 4.0L Power Tech I-6 engine, and Sport models). With the four-speed automatic transmission and Class IV Trailer Tow Group, the 4.0L Power Tech I-6 allows Cherokee to tow up to 5,000 pounds.



*Jeep Cherokee Limited in Deep Amethyst
Many Glacier, Montana*



The standard 2.5L Power Tech I-4 engine on Cherokee SE (two door shown in Stone White) provides 125 horsepower and 150 pound-feet of torque.

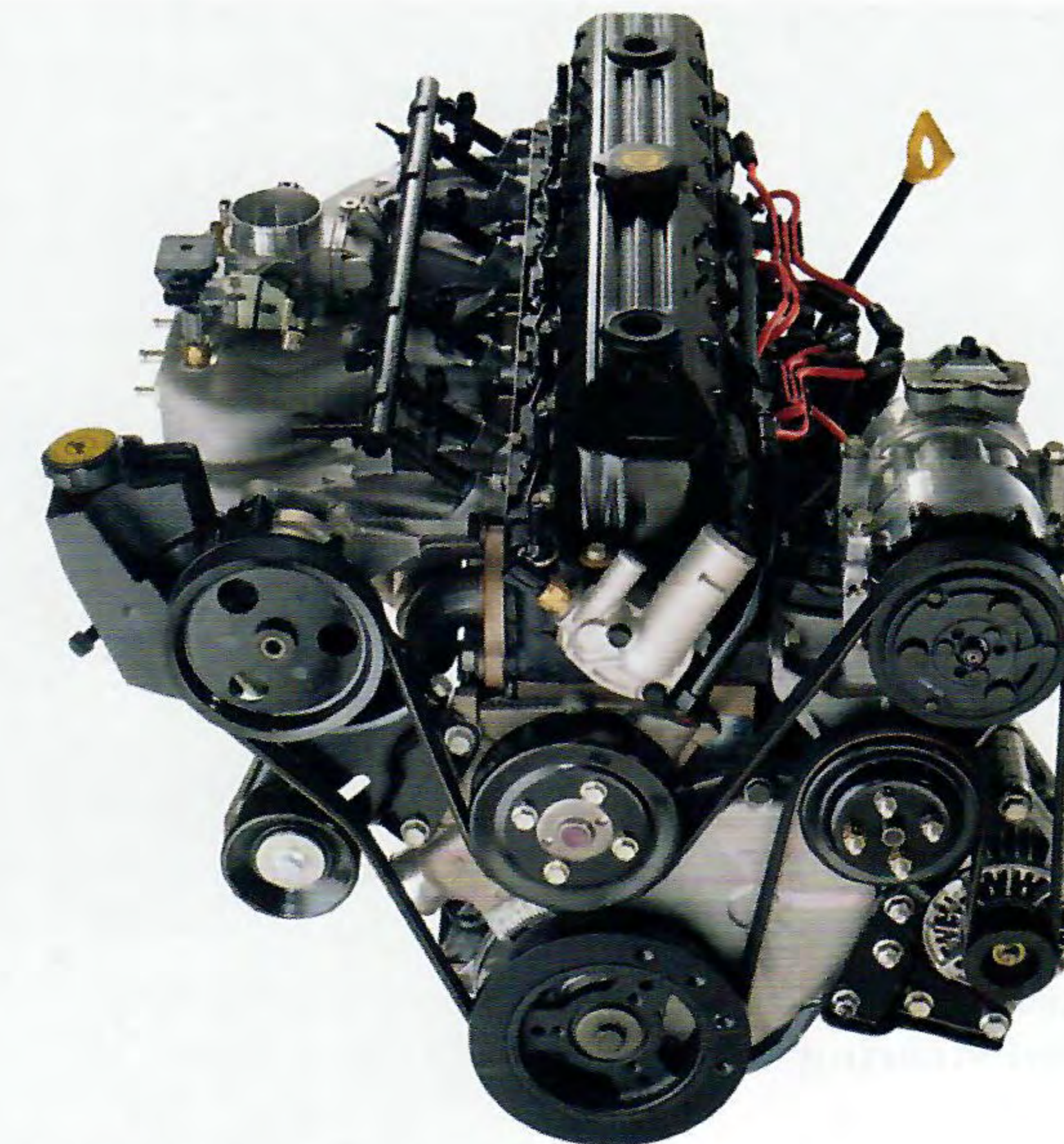

Output for Cherokee's 4.0L Power Tech I-6 engine is 190 horsepower and 225 pound-feet of torque.

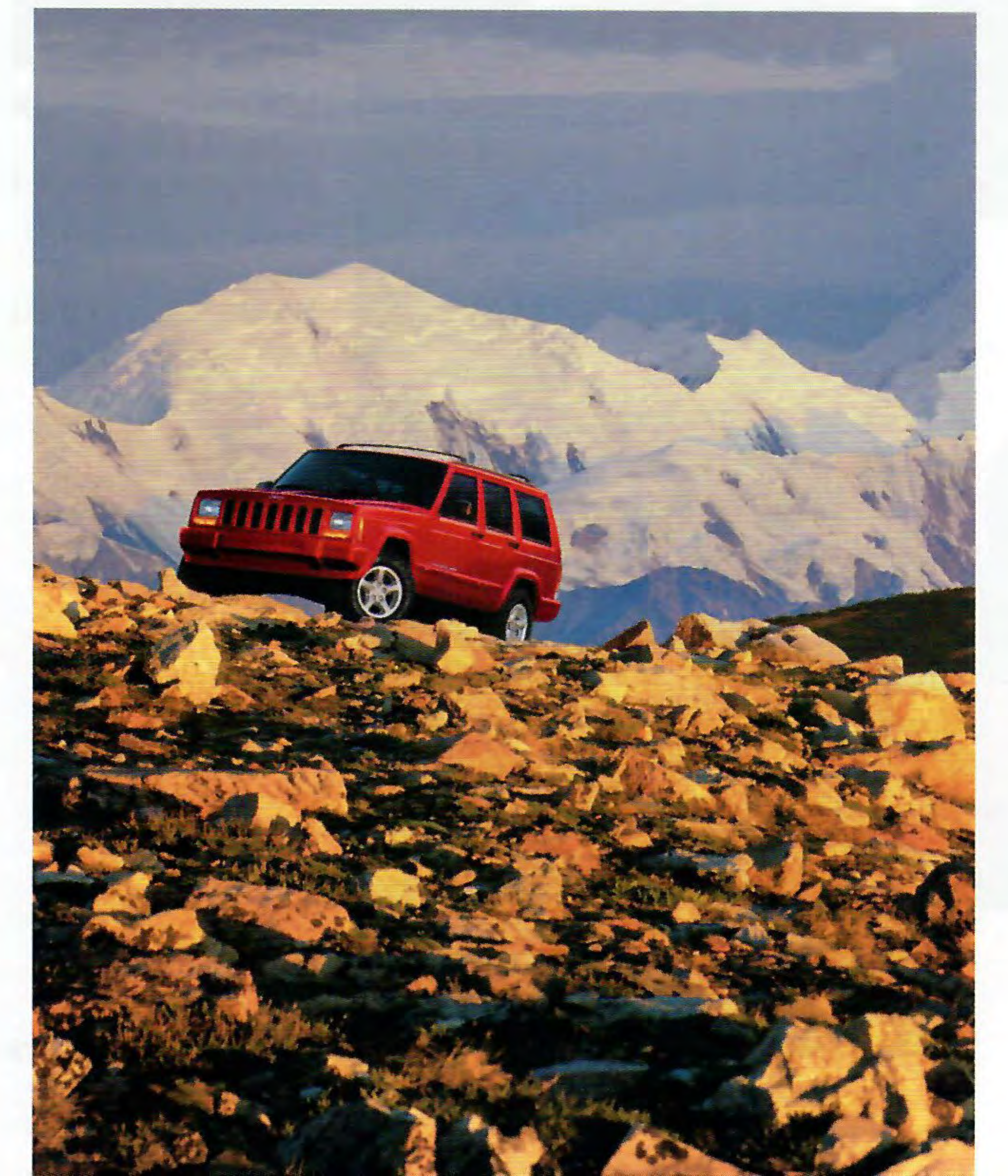



The incredibly rigid, two-piece basic structure of Cherokee's instrument panel (Limited shown) helps keep it quiet inside, even on the bumpiest of trails.

VERSATILITY

What makes Jeep® Cherokee so special is its ability to carry everything you'll need at your destination, over terrain you'd have a hard time crossing on foot. And all that cargo space is easily accessible because the one-piece, all-steel rear liftgate features an interior handle for easy closing. If you run out of room inside, the roof rack (standard on Classic and Limited, optional on SE and Sport) can handle an additional 150 pounds of gear, if needed. As noted in *Automobile Magazine*, "The Cherokee is honest and gimmick free ... with room for bulky cargo and seats for five."

Color and Trim

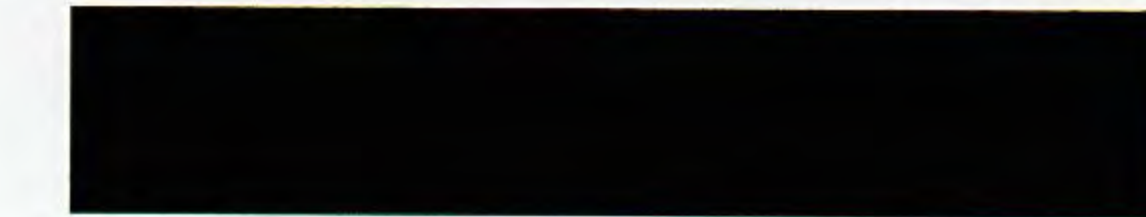

Black



Desert Sand Pearl Coat



Flame Red



Forest Green Pearl Coat



Deep Amethyst Pearl Coat



Chili Pepper Red Pearl Coat



Stone White

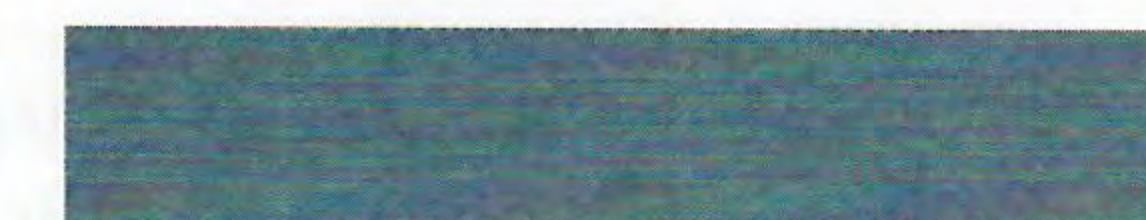

Gunmetal Pearl Coat

Fusion Vinyl. Standard on SE. Shown in Agate, also available in Camel.



Gilmore Cloth. Standard on Sport. Optional on SE. Shown in Agate, also available in Camel.



Grenoble Cloth. Standard on Classic. Shown in Agate, also available in Camel.



Highland Grain Leather trim. Standard on Limited. Shown in Camel, also available in Agate.



Cherokee (Classic cloth interior shown in Agate) offers 32.9 cubic feet of cargo space with the rear seat up. Fold it down and 69.0 cubic feet are available.



Cherokee Limited includes leather-trimmed seating, a leather-wrapped steering wheel and six-way power driver's seat.

New for 1999, heated seats for the driver and front passenger are available on Cherokee Limited. In addition to the standard power driver's seat, this option also includes a power passenger seat.

Properly secure all cargo before transporting.

JEEP® WRANGLER

Out there somewhere is a slice of paradise you've seen only in your dreams. Access is limited — only those who own a Jeep Wrangler may enter. Wrangler's go-anywhere attitude is backed by rock-solid credentials. All models are equipped with Command-Trac®, a part-time, shift-on-the-fly 4WD system. Part-time means you only engage 4WD when you need it — off-road or on slick surfaces. Shift-on-the-fly lets you move from 2WD to 4WD high range at speeds up to 55 mph. Wrangler's Quadra-Coil™ suspension soaks up bumps and offers incredible articulation that helps keep all four wheels on the ground in rocky terrain.

“The Wrangler can do things other SUVs can't, and it goes about its task in a way that others simply wouldn't dare.”
— *Automobile Magazine*



“The Wrangler took to the terrain like a third-grader hitting the playground at recess.”
— *Business Week*

Jeep Wrangler SE in Flame Red
Near Dubinky Wells, Utah

Wrangler's off-road prowess is due in part to its solid Command-Trac transfer case. In 4WD, both front and rear driveshafts are mechanically locked and always turn at the same speed, forming a single driving unit. This is a rigid connection that does not allow for any differential action between front and rear axles.

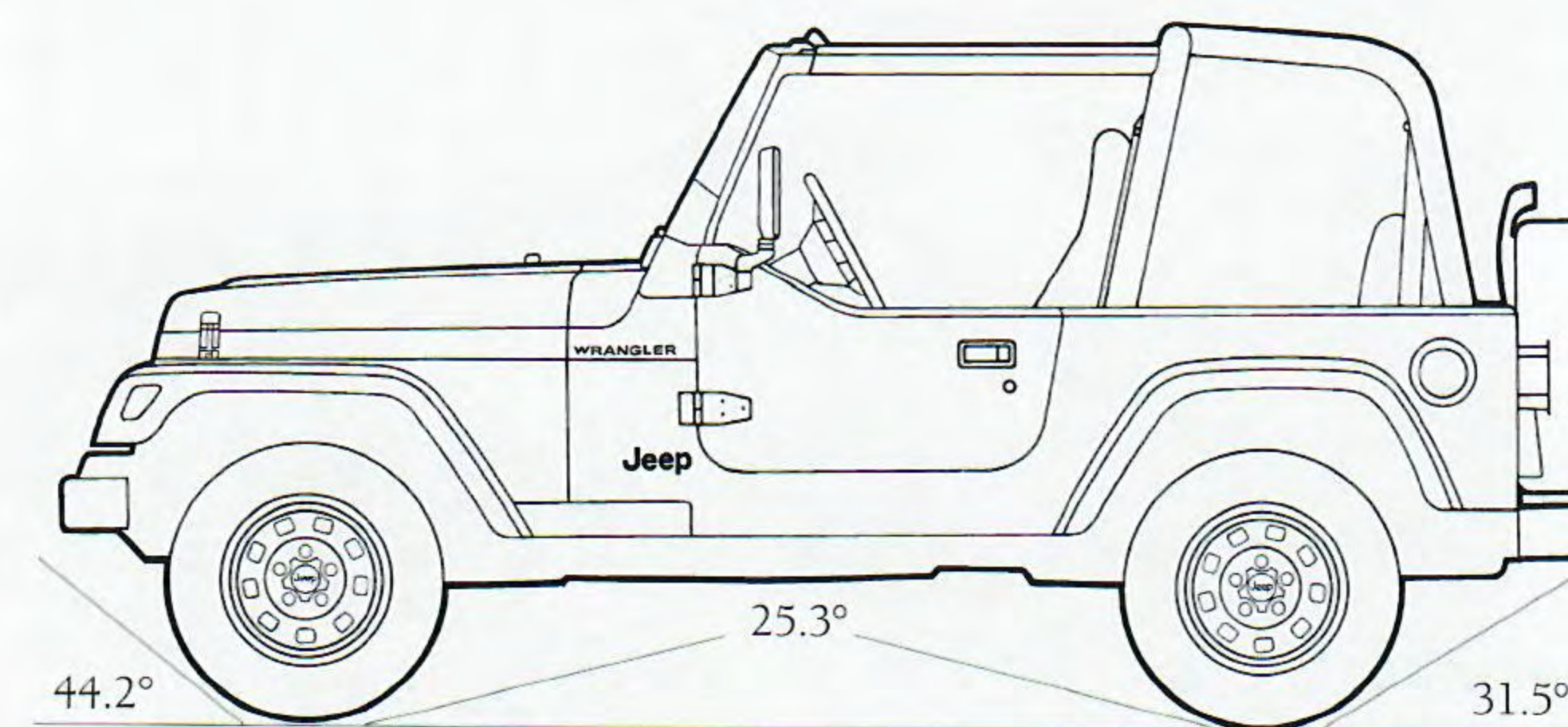
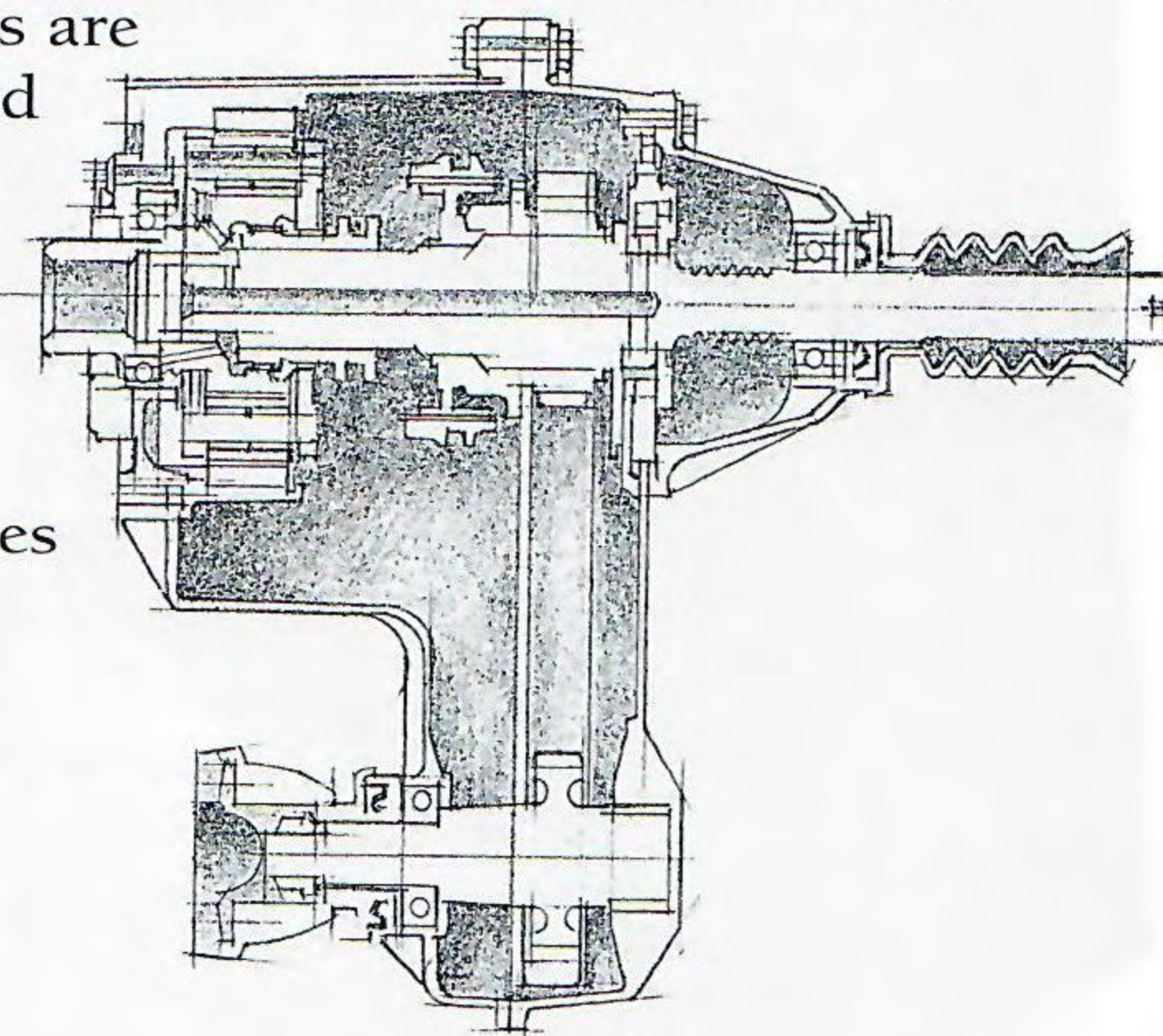

44.2-degree approach, 31.5-degree departure and 25.3-degree breakover angles help keep Wrangler's undercarriage from coming in contact with the ground while traversing rugged terrain.

In 4WD, the engine's power is split by mechanically locking the front and rear driveshafts together, providing torque to all wheels for maximum traction. Since this mode is only intended for slippery conditions, shift back into 2WD when returning to dry, paved surfaces.

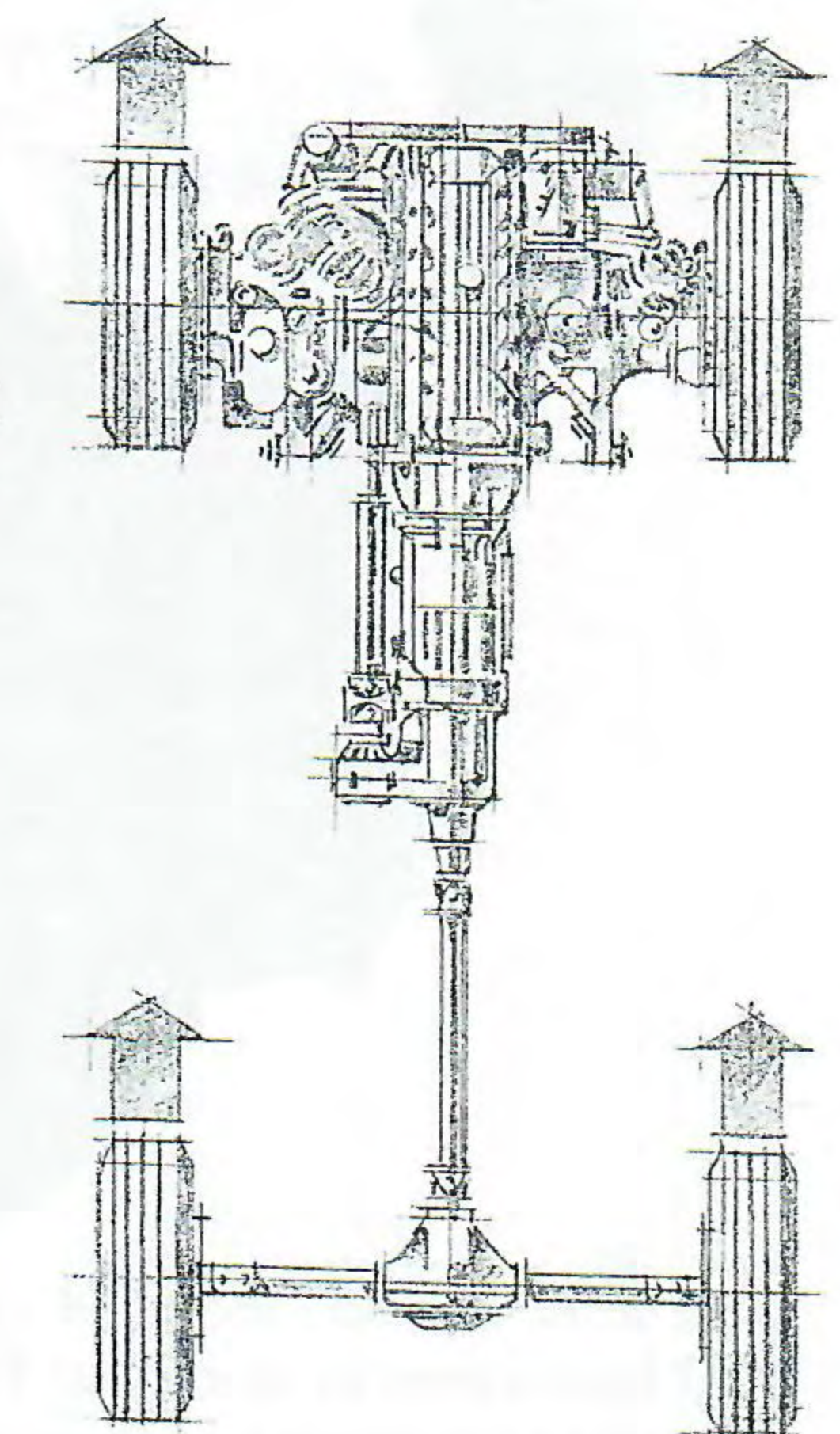

Engage Wrangler's high-range four-wheel drive simply by shifting the Command-Trac lever from 2H to 4H at speeds up to 55 mph.





Jeep Wrangler Sahara in Desert Sand
Monitor Pass, near Topaz, California

POWER

When the U.S. Army requested “light reconnaissance vehicle” prototypes in 1940, only the Willys-Overland Quad exceeded initial power specifications. That powerful heritage lives on in today’s Wrangler. The 4.0L Power Tech I-6 engine, standard on Sport and Sahara, is one of the most powerful six-cylinder engines in its class, turning out 181 horsepower and 222 lb-ft of torque. The 2.5L Power Tech I-4 engine, standard on Wrangler SE, also delivers lots of low-end capability for crawling over rocks and boulders. A standard five-speed manual or optional three-speed automatic transmission is available with either engine. In addition to the standard 4.0L Power-Tech I-6, the well-equipped, top-of-the-line Sahara also features a standard heavy-duty battery, heavy-duty alternator and two front tow hooks.



The 2.5L Power Tech I-4 engine, standard on SE, delivers 120 horsepower and 140 lb-ft of torque. A five-speed manual transmission is standard and a three-speed automatic is optional.

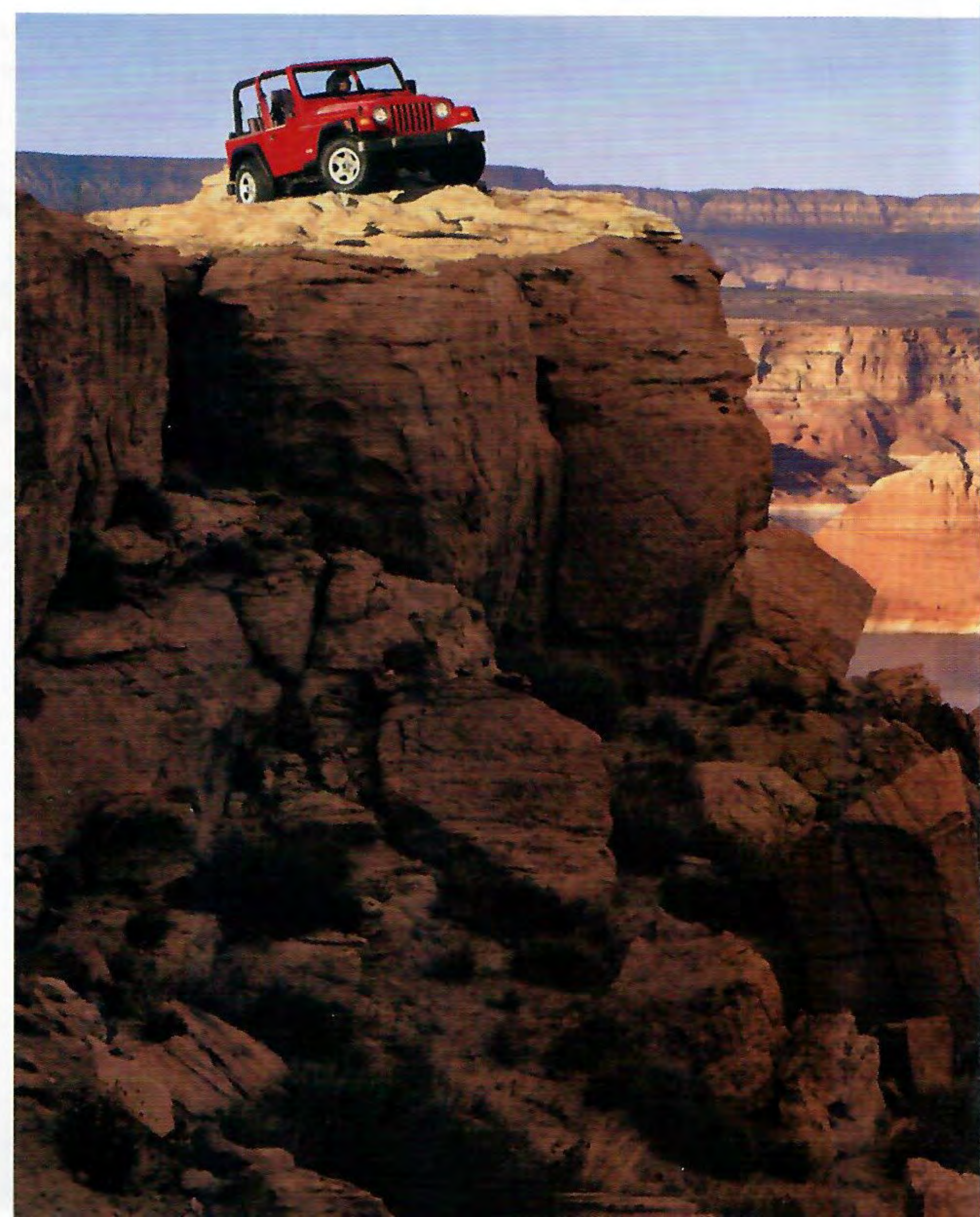

Both the 2.5L Power Tech I-4 and the 4.0L Power Tech I-6 engines have plenty of torque available at the low-end — a necessity in negotiating severe off-road conditions.



Wrangler Sahara Trailcloth interior in Dark Green/Camel

Properly secure all cargo before transporting.



To keep you in control, ergonomically located gauges and levers are easily accessed. A new climate control system with rotary dials features bi-level air circulation that warms or cools your feet and face simultaneously.



Wrangler's convenient Dual-Top option allows you to order both the soft top and the hardtop at the same time you order your vehicle. Dark Tan soft top shown; also available in Stone White or Black.

VERSATILITY

Wilderness outside. Comforting accommodations inside. Wrangler's reclining, high-back front bucket seats feature lateral support wings to hold you in place. And whether you're commuting to work or communing with nature, Wrangler makes it easy to enjoy the openness of the experience. The standard soft top features forward latches instead of snaps, making it simple to fold down. Before driving off-road, you can remove the doors and fold the windshield down.* And since feeling free is best when you're also feeling secure, Next Generation driver and front-passenger air bags† are standard on Wrangler. The front-passenger air bag features a new weatherized on/off switch for added safety and convenience.

* Doors or soft door window frames should not be stored in vehicle.
 † Certified to the Federal Regulations that allow less forceful air bags. Always use seat belts. Remember a backseat is the safest place for children. Rearward-facing child seat can be used in the front seat only with the passenger air bag turned off.



If only your house was this easy to clean. Removable carpet, drain plugs in the floor and water resistant seat fabrics allow Wrangler to be hosed down between adventures.

Color and Trim

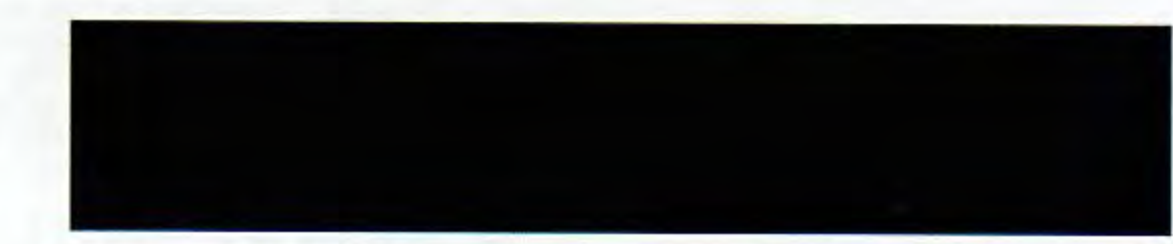

Black (SE, Sport, Sahara)



Flame Red (SE, Sport)



Stone White (SE, Sport, Sahara)



Forest Green Pearl Coat (SE, Sport, Sahara)



Chili Pepper Red Pearl Coat (SE, Sport)



Desert Sand Pearl Coat (SE, Sport, Sahara)



Intense Blue Pearl Coat (SE, Sport)



Deep Amethyst Pearl Coat (SE, Sport)



Gunmetal Pearl Coat (SE, Sport)



Medium Fern Green Pearl Coat (SE, Sport)

Fusion Vinyl. Standard on SE and Sport. Shown in Camel, also available in Agate.



Pueblo Cloth. Optional on SE and Sport. Shown in Agate, also available in Camel.



Trailcloth. Standard on Sahara. Available only in Dark Green/Camel.



FEATURES

Grand Cherokee Laredo selected standard features:

- 4.0L Power Tech I-6 engine
- Four-speed automatic transmission
- Selec-Trac® NV242 full-time 4WD (on 4WD models)
- 16-inch x 7-inch Timberline cast aluminum wheels
- P225/75R16 Goodyear Wrangler ST all-season tires
- Four-wheel disc antilock brake system (ABS)
- Quad-halogen headlamps with delay feature
- 20.5-gallon fuel tank with brush guard
- Stainless steel exhaust system
- Roof rack
- Bright grille
- Flipper liftgate glass
- Rear window defroster
- Rear window wiper/washer
- Spare tire mounted inside under rear load floor
- Next Generation driver and front-passenger air bags*
- Child-protection rear door locks
- Power door locks with illuminated controls
- Power windows with illuminated controls and driver one-touch-down feature
- Dual foldaway power remote exterior mirrors with illuminated controls
- Remote keyless entry system with panic button
- Air conditioning
- AM/FM stereo radio with cassette tape player and six speakers
- Electronic speed control
- Intermittent windshield wipers
- Tilt steering column
- Floor-mounted center console
- Dual cloth-covered visor vanity mirrors

- Easy-fold rear seat with height-adjustable folding outboard head restraints
- Height-adjustable shoulder belts for front and rear outboard seating positions
- 40/60 split-folding rear seats

Grand Cherokee Limited adds these selected standard features:

- 16-inch x 7-inch Silverblade cast aluminum wheels
- P245/70R16 Goodyear Eagle LS all-season performance tires
- Quadra-Trac II™ NV247 on-demand 4WD (on 4WD models)
- Body-color grille, fascias and door handles
- Fog lamps
- Power mirrors with heat, memory and driver-side autodimming features
- Sunscreen glass
- Infrared Dual Zone Climate Control
- Programmable overhead console with trip computer, compass, temperature
- HomeLink® Universal Transmitter
- Jeep Memory System
- Wanderer II leather-trimmed seating
- Leather-trimmed power seats with memory feature and seatback map pockets
- Leather-wrapped steering wheel with radio controls
- AM/FM stereo radio with CD and cassette players, eight speaker Infinity Gold® Sound System, 180-watt amplifier and memory feature
- Luxury Group, includes autodimming rearview mirror, automatic headlamps and 10-way power seats
- Vehicle Theft Security System with security alarm and Sentry Key™ Engine Immobilizer
- Rear cargo area power outlet and covered cargo panel storage bin

FEATURES

Cherokee SE selected standard features:

- 2.5L Power Tech I-4 engine
- Five-speed manual transmission
- Command-Trac® NV231 part-time 4WD (on 4WD models)
- 15-inch x 7-inch Styled steel wheels
- P215/75R15 Goodyear Wrangler AP all-season tires
- 20-gallon fuel tank capacity
- Next Generation driver and front-passenger air bags*
- Child-protection rear door locks (four-door models only)
- Full-center floor console includes cup holders, covered storage, padded armrest and storage bin with slots for CD/cassettes
- AM/FM stereo radio with two front-door speakers
- Height-adjustable front shoulder belts with traveling inboard buckles
- Intermittent windshield wipers
- Rear window defroster

Cherokee Sport adds these selected standard features:

- 4.0L Power Tech I-6 engine
- 15-inch x 7-inch Full-face steel wheels
- P225/75R15 Goodyear Wrangler RT/S outline white letter all-terrain tires
- Body-color bumpers, grille, headlamp bezels and fender flares
- Black bodyside molding
- AM/FM stereo radio with cassette tape player and four speakers (two in the front doors and two in the rear headliner)

Cherokee Classic adds these selected standard features:

- Four-speed automatic transmission
- 15-inch x 7-inch Ecco cast aluminum wheels painted Dark Quartz

FEATURES

Wrangler SE selected standard features:

- 2.5L Power Tech I-4 engine
- Five-speed manual transmission
- Command-Trac® NV231 part-time 4WD
- Quadra-Coil™ suspension includes live solid axles, locating arms, coil springs, track and stabilizer bars and gas-charged shock absorbers
- 15-inch x 6-inch Styled steel wheels
- P205/75R15 Goodyear Wrangler RT/S all-terrain tires
- Fuel tank and transfer case skid plates
- 15-gallon fuel tank capacity
- 500-ampere battery
- Next Generation driver and front-passenger air bags* with weatherized front-passenger air bag on/off switch
- Power steering
- Locking glove box
- Fusion vinyl reclining front bucket seats with tip-and-slide front-passenger seat
- Height-adjustable front shoulder belts with traveling inboard buckles
- Mini-floor console with cup holder and tray
- Easy-fold soft top
- Low fuel warning lamp
- Dual swingaway mirrors
- Removable front carpeting

Wrangler Sport adds these selected standard features:

- 4.0L Power Tech I-6 engine
- 15-inch x 7-inch Full-face steel wheels

- P215/75R15 Goodyear Wrangler RT/S all-terrain tires
- AM/FM stereo radio with clock and two speakers
- Fold-and-Tumble™ rear seat
- Removable cargo area carpeting

Wrangler Sahara adds these selected standard features:

- 15-inch x 7-inch Grizzly cast aluminum wheels
- P225/75R15 Goodyear Wrangler GS-A outline white letter all-terrain tires
- 19-gallon fuel tank capacity
- Two front tow hooks
- Electrical Group includes 117-ampere alternator, 600-ampere battery
- Round halogen fog lamps
- Body-color fender flares with rocker molding
- Bodyside steps
- "Sahara" spare tire cover
- Trailcloth seating with front seatback map pockets and EZ access driver seat
- AM/FM stereo radio with cassette tape player and four speakers (two in the instrument panel and two in the rear overhead sound bar)
- Leather-wrapped steering wheel
- Height-adjustable steering column
- Intermittent windshield wipers
- Front floor mats
- Convenience Group includes courtesy lamp under instrument panel, engine compartment lamp and a full-center floor console

- Body-color exterior features
- Power remote exterior mirrors
- Roof rack
- Rear wiper/washer, intermittent
- Leather-wrapped steering wheel

Cherokee Limited adds these selected standard features:

- 15-inch x 7-inch Luxury cast aluminum wheels
- P225/70R15 Goodyear Eagle GA vertically serrated black sidewall all-season tires
- Selec-Trac® NV242 full-time 4WD (on 4WD models)
- Bodyside paint stripe
- Six-way power driver's seat
- Air conditioning
- Overhead console includes compass, trip computer, front and rear map/reading lamps and storage for a pair of sunglasses and garage door opener
- Electronic speed control
- Power Equipment Group includes power windows, power door locks and remote keyless entry system with two key fobs
- Light Group includes map/dome, courtesy under instrument panel, cargo area and engine lamps, headlamp time delay and dual illuminated visor vanity mirrors (cargo area lamp is standard on Sport, Classic and Limited)
- Height-adjustable steering column
- Deep-tinted rear door, rear quarter and liftgate glass

*Certified to the Federal Regulations that allow less forceful air bags. Always use seat belts. Remember a backseat is the safest place for children.

If you would like to discuss your equipment choices and vehicle pricing with a knowledgeable advisor before visiting your dealer, call 1-800-925-JEEP or look us up on the Web site at www.jeep.com

*Certified to the Federal Regulations that allow less forceful air bags. Always use seat belts. Remember a backseat is the safest place for children.



Jeep Grand Cherokee Limited in Sienna, Jeep Cherokee Sport in Desert Sand,
Jeep Wrangler SE in Flame Red
Lone Pine, California



Sun Bonnet Combo Kit

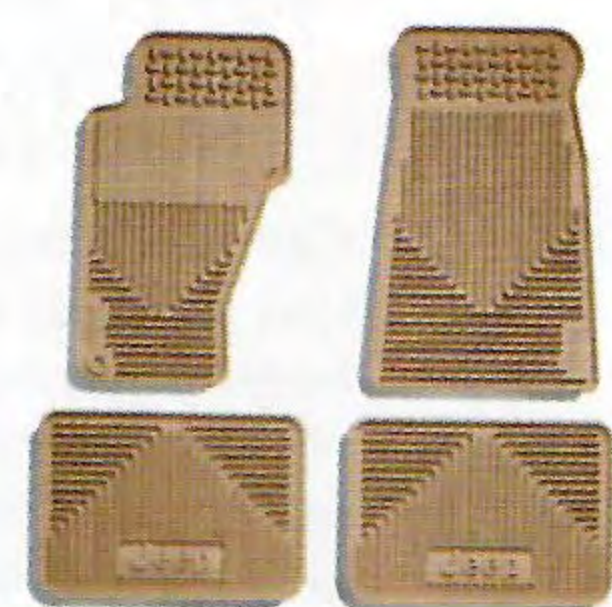

Slush Floor Mats



Six-Disc
CD Changer



AM/FM Stereo
Radio with Cassette
Player, Compact
Disc Player and
Graphic Equalizer



Hitch-Mounted Four-Bike
Carrier

JEEP ACCESSORIES FROM MOPAR

To enhance the appearance and functionality of your vehicle, your dealer offers a complete line of genuine Jeep accessories from Mopar. Created by the same engineers who designed your vehicle, Mopar Accessories are the only ones recognized for quality, fit and finish. Mopar Accessories are covered by the same 3/36 Bumper-to-Bumper Limited Warranty that covers your Jeep vehicle.* So for genuine Jeep accessories, there's only one choice. Get real, get Mopar.

JEEP PROVISIONS

Few 4x4s have fueled our imaginations and stirred our souls like Jeep vehicles. Now's the time to discover a new line of products licensed by the Jeep brand that continues this rich heritage. Our *Jeep Provisions* catalog details page after page of classic gear for the Jeep enthusiast. Apparel to Jeep Boomboxes. Watches to luggage. Rugged and stylish products that are as far from the ordinary as, well, your craving for adventure itself. Products that have one very special word in common: Jeep. For your personal copy, call 1-800-789-JEEP, and discover the reach of this legendary brand.

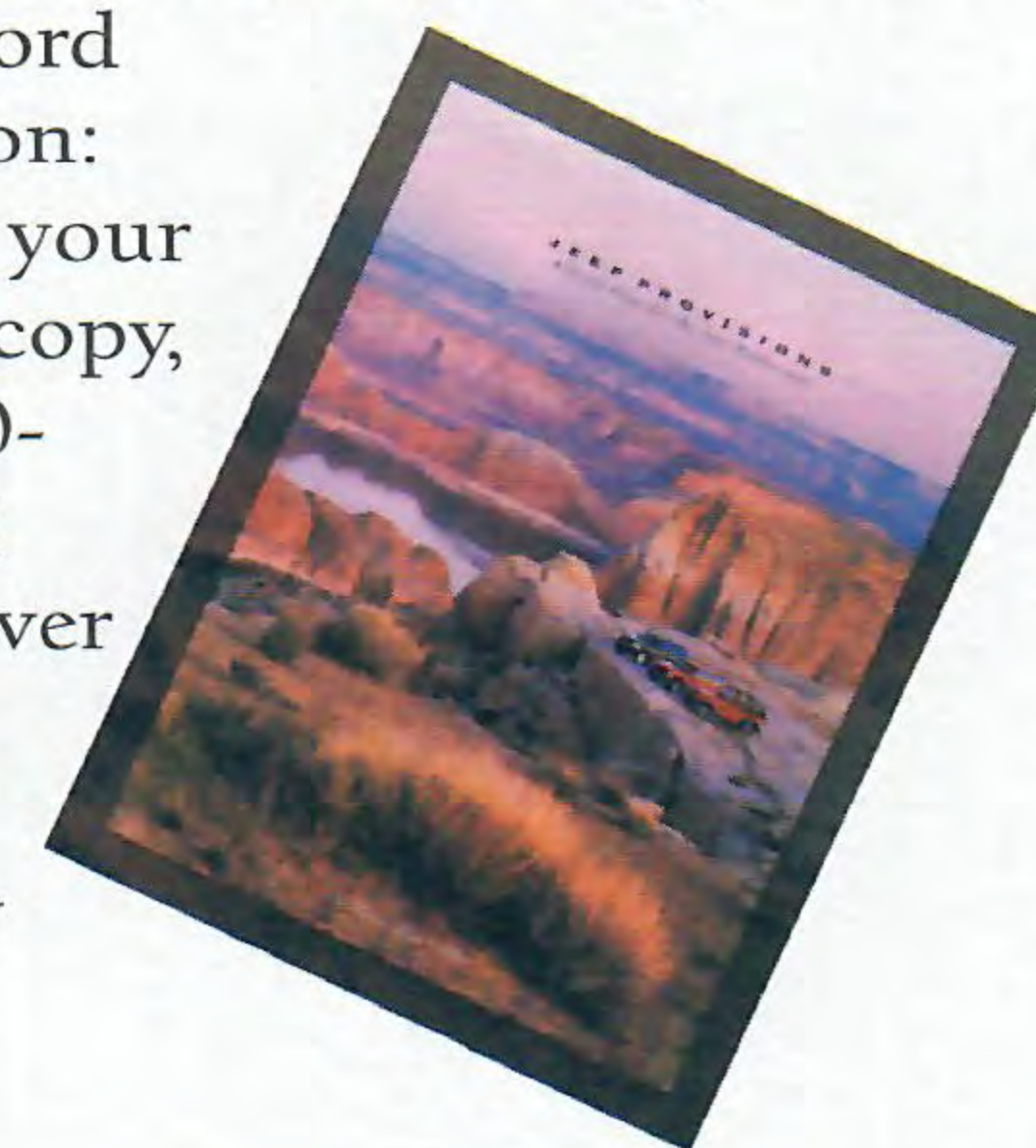

All product illustrations, specifications and competitive comparisons are based upon current information at the time of publication approval. Although descriptions are believed to be correct, complete accuracy cannot be guaranteed. Chrysler Corporation reserves the right to make changes at any time, without notice or obligation, in prices, specifications, equipment, colors and materials, and to change or discontinue models. Some of the equipment shown or described throughout this catalog is available at extra cost. See your dealer for the latest information.

CUSTOMER ONE CARE™

At Chrysler Corporation, our commitment to complete customer satisfaction is evident in every Jeep vehicle we sell. Long after a vehicle is driven away from the showroom, we will be there to ensure that our customers remain pleased with every new-vehicle purchase. To prove this commitment, all Chrysler Corporation vehicles are covered by the 3/36 Customer One Care Plan[†], which includes a 3-year/36,000-mile (whichever comes first) Bumper-to-Bumper Limited Warranty[†] and Roadside Assistance[‡] for 3 years or 36,000 miles. Roadside Assistance provides 24-hour, 7-day-a-week Emergency Road Service, contacted by a nationwide toll-free number. A 5-year or 100,000-mile Outer-Panel Rust-Through Limited Warranty covers the cost of all parts and labor needed to repair exterior sheet metal panels perforated by corrosion. The 3/36 Customer One Care Plan stays with the vehicle, transferring automatically to subsequent owners at no cost during the warranty period.

^{*}See your dealer for additional details and a copy of this limited warranty.
[†]Covers the complete vehicle against defects in materials and workmanship. Excludes wiper blades, clutch and brake linings, brake rotors and drums, normal maintenance items and tires (covered by their own manufacturer's warranty).
[‡]Roadside Assistance services are provided by Cross Country Motor Club, Inc. (In California, Cross Country Motor Club of California, Inc.).

LEASING

Leasing is a popular way to finance a new vehicle, and Chrysler Financial's **Gold Key Lease** has the flexibility to fit your vehicle choice and your lifestyle. Lease payments are typically lower and for a shorter term than conventional financing. At lease end, you can: 1) turn the vehicle in and lease a new one; 2) buy the vehicle and keep it; 3) buy the vehicle and sell it for a possible profit. If the idea of driving the vehicle you want and paying less for it sounds great, ask about Gold Key Lease. **Gold Key Plus** is a great leasing option for customers who want low lease payments and pride of vehicle ownership — Gold Key Plus offers both. Decide how long the vehicle will be driven and the trade-in value is guaranteed (less excess mileage and wear and tear). Ask your dealer for complete details. **Commercial Finance Options (CFO)** offers several finance and lease options to small and midsize businesses, municipalities and small fleet operators. A full range of automotive financing is available through Chrysler Financial, providing flexible payment plans and finance products for qualified buyers. Many of these plans can be customized to fit your particular budget and make your new vehicle even more affordable. **The College Graduate Program** is especially attractive to those just beginning their careers. Ask your salesperson for details about any of the above plans. Chrysler Financial's programs are subject to availability and state and local laws.

Jeep, Jeep Wrangler radiator grille design, Quadra-Trac, Quadra-Drive, Vari-Lok, Quadra-Trac II, Quadra-Coil, Selec-Trac, Sentry Key, Command-Trac, Fold-and-Tumble, Mopar, Customer One Care and Gold Key Lease are trademarks of Chrysler Corporation. HomeLink is a registered trademark of the Prince Corporation. Infinity Gold is a trademark of Infinity Systems, Inc.

For 13 years, we have partnered with Tread Lightly! to promote responsible off-road driving. As a founding member and official sponsor, we urge all Jeep vehicle owners to follow Tread Lightly! guidelines such as "Use common sense and stay on marked trails." To learn more

treadlightly![®]
LEAVING A GOOD IMPRESSION



about how you can participate, call 1-800-966-9900 (or visit their World Wide Web site at www.treadlightly.org). By protecting our land for the future, we'll all be more richly rewarded.

Jeep

T H E R E ' S O N L Y O N E

For more information, call 1-800-925-JEEP, or visit our World Wide Web site at www.jeep.com

Jeep is a registered trademark of Chrysler Corporation.

Form no. 74-383-9945 8/98 (900M) Litho in USA